

6/30/2023

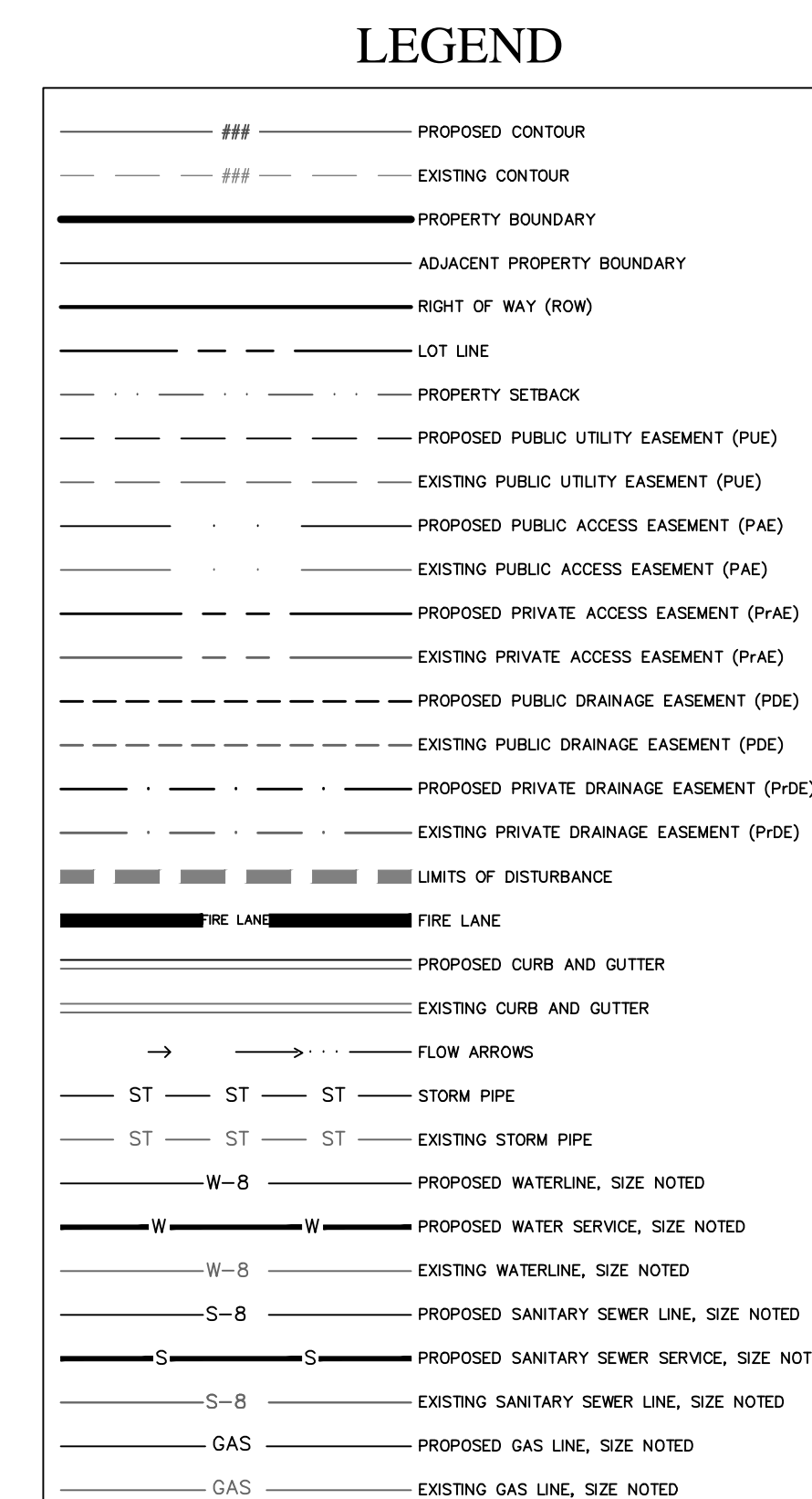

REVISIONS	
NUMBER	DATE

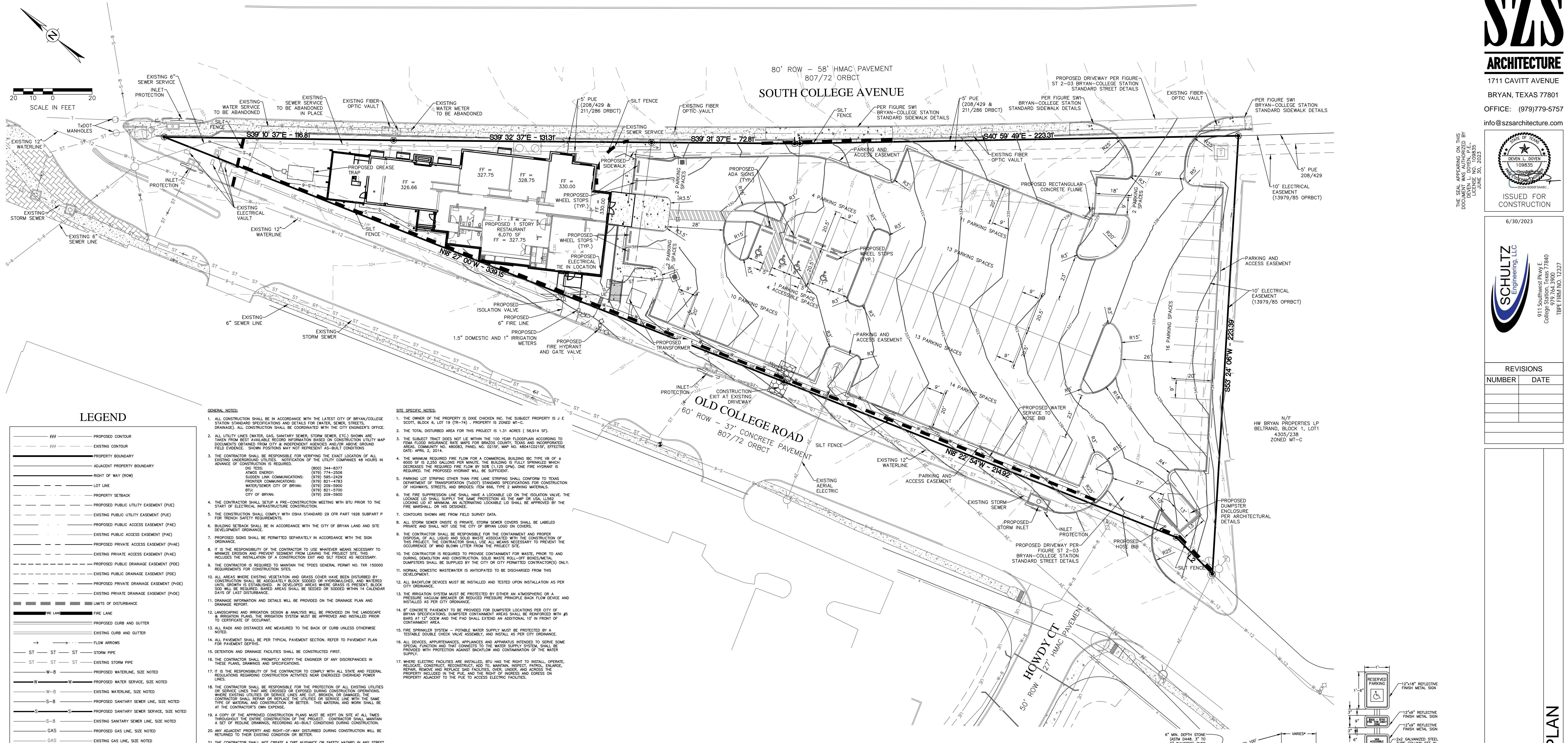

- ### GENERAL NOTES:
- ALL CONSTRUCTION SHALL BE IN ACCORDANCE WITH THE LATEST CITY OF BRYAN/COLLEGE STATION STANDARD SPECIFICATIONS AND DETAILS FOR WATER, SEWER, STREETS, DRAINAGE. ALL CONSTRUCTION SHALL BE COORDINATED WITH THE CITY ENGINEER'S OFFICE.
  - ALL UTILITY LINES (WATER, GAS, SANITARY SEWER, STORM SEWER, ETC.) SHOWN ARE TAKEN FROM BEST AVAILABLE RECORD INFORMATION BASED ON CONSTRUCTION UTILITY MAP DOCUMENTS OBTAINED FROM CITY & INDEPENDENT AGENCIES AND/OR ABOVE GROUND FIELD SURVEY. SHOWN POSITIONS MAY NOT REPRESENT AS-BUILT CONDITIONS.
  - THE CONTRACTOR SHALL BE RESPONSIBLE FOR VERIFYING THE EXACT LOCATION OF ALL EXISTING UNDERGROUND UTILITIES. NOTIFICATION OF THE UTILITY COMPANIES 48 HOURS IN ADVANCE OF CONSTRUCTION IS REQUIRED.  
DOW TRENCH (800) 344-8377  
AMCO ENERGY (979) 774-2295  
TRENCH LINK COMMUNICATIONS (979) 599-5428  
FRONTIER COMMUNICATIONS (979) 821-4783  
WATERS/SEWER CITY OF BRYAN (979) 329-5700  
BTLU (979) 329-5900  
CITY OF BRYAN (979) 329-5900
  - THE CONTRACTOR SHALL SETUP A PRE-CONSTRUCTION MEETING WITH BTU PRIOR TO THE START OF ELECTRICAL INFRASTRUCTURE CONSTRUCTION.
  - THE CONTRACTOR SHALL COMPLY WITH OSHA STANDARD 29 CFR PART 1926 SUBPART P FOR TRENCH SAFETY REQUIREMENTS.
  - BUILDING SETBACK SHALL BE IN ACCORDANCE WITH THE CITY OF BRYAN LAND USE AND DEVELOPMENT ORDINANCE.
  - PROPOSED SIGNS SHALL BE PERMITTED SEPARATELY IN ACCORDANCE WITH THE SIGN ORDINANCE.
  - IT IS THE RESPONSIBILITY OF THE CONTRACTOR TO USE WHATEVER MEANS NECESSARY TO MANAGE EROSION AND PREVENT SEDIMENT FROM LEAVING THE PROJECT SITE. THIS INCLUDES THE INSTALLATION OF A CONSTRUCTION EROSION CONTROL PLAN (CECP) AND THE INSTALLATION OF A CONSTRUCTION SEDIMENT CONTROL PLAN (CSCP) AS REQUIRED BY THE CITY OF BRYAN.
  - THE CONTRACTOR IS REQUIRED TO MAINTAIN THE TRODS GENERAL PERMIT NO. 106 150000 REQUIREMENTS FOR CONSTRUCTION SITES.
  - ALL AREAS WHERE EXISTING VEGETATION AND GRASS COVER HAVE BEEN DISTURBED BY CONSTRUCTION SHALL BE REVEGETATED WITH SEEDS OF HYDRALMORPHIC AND WATERED REGULARLY. SEEDS SHALL BE APPLIED AT A RATE OF 100 LBS PER ACRE. A MULCH SHALL BE APPLIED TO PROTECT SEEDS FROM BIRDS AND OTHER ANIMALS. MULCH SHALL BE APPLIED WITHIN 14 CALENDAR DAYS OF LAST DISTURBANCE.
  - DRAINAGE INFORMATION AND DETAILS WILL BE PROVIDED ON THE DRAINAGE PLAN AND DRAINAGE REPORT.
  - LANDSCAPING AND IRRIGATION DESIGN & ANALYSIS WILL BE PROVIDED ON THE LANDSCAPE IRRIGATION PLANS. THE IRRIGATION SYSTEM MUST BE APPROVED AND INSTALLED PRIOR TO OCCUPANCY.
  - ALL RADII AND DISTANCES ARE MEASURED TO THE BACK OF CURB UNLESS OTHERWISE NOTED.
  - ALL PAVEMENT SHALL BE PER TYPICAL PAVEMENT SECTION. REFER TO PAVEMENT PLAN FOR PAVEMENT DETAILS.
  - DETENTION AND DRAINAGE FACILITIES SHALL BE CONSTRUCTED FIRST.
  - THE CONTRACTOR SHALL PROMPTLY NOTIFY THE ENGINEER OF ANY DISCREPANCIES IN THESE PLANS, DRAWINGS AND SPECIFICATIONS.
  - IT IS THE RESPONSIBILITY OF THE CONTRACTOR TO COMPLY WITH ALL STATE AND FEDERAL REGULATIONS REGARDING CONSTRUCTION ACTIVITIES NEAR ENERGIZED OVERHEAD POWER LINES.
  - THE CONTRACTOR SHALL BE RESPONSIBLE FOR THE PROTECTION OF ALL EXISTING UTILITIES OR SERVICE LINES THAT ARE EXPOSED OR EXPOSED DURING CONSTRUCTION OPERATIONS. WHERE EXISTING UTILITIES OR SERVICE LINES ARE CUT, BROKEN, OR DAMAGED, THE CONTRACTOR SHALL REPAIR OR REPLACE THE UTILITIES OR SERVICE LINES WITH THE SAME TYPE OF MATERIAL AND CONSTRUCTION OR BETTER. THIS MATERIAL AND WORK SHALL BE AT THE CONTRACTOR'S OWN EXPENSE.
  - A COPY OF THE APPROVED CONSTRUCTION PLANS MUST BE KEPT ON SITE AT ALL TIMES THROUGHOUT THE ENTIRE CONSTRUCTION OF THE PROJECT. CONSTRUCTION SHALL MAINTAIN A SET OF REDLINE DRAWINGS, RECORDING AS-BUILT CONDITIONS DURING CONSTRUCTION.
  - ANY ADJACENT PROPERTY AND RIGHT-OF-WAY DISTURBED DURING CONSTRUCTION WILL BE RETURNED TO THEIR EXISTING CONDITION OR BETTER.
  - THE CONTRACTOR SHALL NOT CREATE A DIRT NUISANCE OR SAFETY HAZARD IN ANY STREET OR DRIVEWAY.
  - ADJACENT DRAINAGE SHALL BE MAINTAINED AT ALL TIMES DURING CONSTRUCTION AND ANY DRAINAGE DITCH OR STRUCTURE DISTURBED DURING CONSTRUCTION SHALL BE RESTORED TO EXISTING CONDITION OR BETTER.
  - THE CONTRACTOR SHALL PROTECT ALL MONUMENTS, IRON PINS, AND PROPERTY CORNERS DURING CONSTRUCTION.
  - THE IRRIGATION SYSTEM WILL BE PROTECTED BY EITHER A PRESSURE VACUUM BREAKER OR REDUCED PRESSURE PRINCIPLE BACK FLOW DEVICE OR A DOUBLE-CHECK BACK FLOW DEVICE. AN INSTALLED AS PER ORDINANCE 238A.
  - ALL BACK FLOW DEVICES WILL BE INSTALLED AND TESTED UPON INSTALLATION.
  - THE CONTRACTOR MAY OBTAIN AN ELECTRONIC COPY OF THESE PLANS FOR CONSTRUCTION PURPOSES. THE ELECTRONIC FILE AND INFORMATION GENERATED BY SCHULTZ ENGINEERING, LLC FOR THIS PROJECT IS CONSIDERED BY US TO BE CONFIDENTIAL. WHEN SHARED, IT IS TO BE USED ONLY FOR THE INDIVIDUAL OR ENTITY TO WHOM IT IS ADDRESSED. PERMISSION IS NOT GRANTED TO THE RECIPIENT FOR DISTRIBUTION OF THE ELECTRONIC FILE OR ANY PART THEREOF. THE RECIPIENT UNDERSTANDS THAT THIS DATA IS AUTHORIZED AS IS WITHOUT ANY WARRANTY AS TO ITS PERFORMANCE, ACCURACY, COMPLETENESS, OR AS TO ANY RESULTS GENERATED THROUGH ITS USE. THE RECIPIENT ALSO UNDERSTANDS AND AGREES THAT UPON RELEASE OF SUCH DATA, US SHALL BE RELEASED FROM ALL LIABILITY FOR THE USE OR MODIFICATION, THE USER AND RECIPIENT OF THE ELECTRONIC DATA ACCEPTS FULL RESPONSIBILITY AND LIABILITY FOR ANY CONSEQUENCES ARISING OUT OF THEIR USE.
  - CURB DETAILS REFER TO BRYAN - COLLEGE STATION STANDARD STREET DETAILS SHEET (FIGURE ST, SHEET 1 OF 2).

- ### SITE SPECIFIC NOTES:
- THE OWNER OF THE PROPERTY IS DIXIE CHICKEN INC. THE SUBJECT PROPERTY IS J E SCOTT, BLOCK 6, LOT 19 (19-74). PROPERTY IS ZONED MFC-C.
  - THE TOTAL DISTURBED AREA FOR THIS PROJECT IS 1.31 ACRES (58,914 SF).
  - THE SUBJECT TRACT DOES NOT LIE WITHIN THE 100 YEAR FLOODPLAIN ACCORDING TO FEMA FLOOD INSURANCE RATE MAP FOR BRAZOS COUNTY, TEXAS AND INCORPORATED AREAS. COMMUNITY NO. 48008A, PANEL NO. 0215F, MAP NO. 484410215F, EFFECTIVE DATE APRIL 2, 2014.
  - THE MINIMUM REQUIRED FLOW FOR A COMMERCIAL BUILDING IS 1.5 GPM PER 100 SF OF FLOOR AREA. THE BUILDING IS FULLY SPRINKLED WHICH DECREASES THE REQUIRED FLOW BY 50% (1.125 GPM). ONE FIRE HYDRANT IS REQUIRED. THE PROPOSED HYDRANT WILL BE SUFFICIENT.
  - PARKING LOT STRIPING OTHER THAN FIRE LANE STRIPING SHALL CONFORM TO TEXAS DEPARTMENT OF TRANSPORTATION (TxDOT) STANDARD SPECIFICATIONS FOR CONSTRUCTION OF HIGHWAYS, STREETS, AND BRIDGES, FPM 600, TYPE 2 MARKING MATERIALS.
  - THE FIRE SUPPRESSION LINE SHALL HAVE A LOCKABLE LID ON THE ISOLATION VALVE. THE LOCKABLE LID SHALL SUPPLY THE SAME PROTECTION AS THE AMP OR USA L1562 LOCKING LID AT MINIMUM. AN ALTERNATING LOCKABLE LID SHALL BE APPROVED BY THE FIRE MARSHAL, OR HIS DESIGNEE.
  - CONTOURS SHOWN ARE FROM FIELD SURVEY DATA.
  - ALL STORM SEWER COVERS IS PRIVATE. STORM SEWER COVERS SHALL BE LABELED PRIVATE AND SHALL NOT USE THE CITY OF BRYAN LOGO ON COVERS.
  - THE CONTRACTOR SHALL BE RESPONSIBLE FOR THE CONTAINMENT AND PROPER DISPOSAL OF ALL LIQUID AND SOLID WASTE ASSOCIATED WITH THE CONSTRUCTION OF THIS PROJECT. THE CONTRACTOR SHALL USE ALL MEANS NECESSARY TO PREVENT THE OCCURRENCE OF WIND BLOWN LITTER FROM THE PROJECT SITE.
  - THE CONTRACTOR IS REQUIRED TO PROVIDE CONTAINMENT FOR WASTE, PRIOR TO AND DURING DEMOLITION AND CONSTRUCTION. SOLID WASTE SHALL BE STORED IN METAL DUMPSTERS SHALL BE SUPPLIED BY THE CITY OR CITY PERMITTED CONTRACTOR(S) ONLY.
  - NORMAL DOMESTIC WASTEWATER IS ANTICIPATED TO BE DISCHARGED FROM THIS DEVELOPMENT.
  - THE IRRIGATION SYSTEM MUST BE PROTECTED BY EITHER AN ATMOSPHERIC OR A PRESSURE VACUUM BREAKER OR REDUCED PRESSURE PRINCIPLE BACK FLOW DEVICE AND INSTALLED AS PER CITY ORDINANCE.
  - 8" CONCRETE PAVEMENT TO BE PROVIDED FOR DUMPSTER LOCATIONS PER CITY OF BRYAN SPECIFICATIONS. DUMPSTER CONTAINMENT AREAS SHALL BE REINFORCED WITH #5 BARS AT 12" O.C. AND THE PAIS SHALL EXTEND AN ADDITIONAL 10' IN FRONT OF CONTAINMENT AREA.
  - THE IRRIGATION SYSTEM - PORTABLE WATER SUPPLY MUST BE PROTECTED BY A TESTABLE DOUBLE CHECK VALVE ASSEMBLY, AND INSTALL AS PER CITY ORDINANCE.
  - ALL DEVICES, APPURTENANCES, APPLIANCES AND APPARATUS INTENDED TO SERVE SOME SPECIAL FUNCTION AND THAT CONNECTS TO THE WATER SUPPLY SYSTEM SHALL BE PROVIDED WITH PROTECTION AGAINST BACKFLOW AND CONTAMINATION OF THE WATER SUPPLY.
  - WHERE ELECTRIC FACILITIES ARE INSTALLED, BTU HAS THE RIGHT TO INSTALL, OPERATE, MAINTAIN, REPAIR, REPLACE AND FACILITIES, OVER, UNDER, AND ACROSS THE PROPERTY INCLUDED IN THE PLAN AND THE RIGHT OF WORDS AND DEPRESS ON PROPERTY ADJACENT TO THE PUE TO ACCESS ELECTRIC FACILITIES.

### PARKING ANALYSIS

REQUIRED PARKING	6,070 SF OF RESTAURANT
1.25 SPACES PER 100 SF	(SQ OUT IN SW SET)
PROPOSED PARKING	76 SPACES REQUIRED
88 SPACES PARKING	(SQ OUT IN SW SET)
4 SPACES ACCESSIBLE PARKING	(SQ OUT IN SW SET)
92 SPACES PROVIDED	

### BENCHMARK INFORMATION

BTM 1	N: 16688.4590 E: 47984.0270 ELEV.: 336.494 (SQ OUT IN SW SET)
BTM 1	N: 17023.2500 E: 47682.5670 ELEV.: 324.235 (SQ OUT IN SW SET)
BTM 1	N: 16721.4970 E: 47633.5830 ELEV.: 328.035 (SQ OUT IN SW SET)

### CHICKEN OIL COMPANY

3600 S COLLEGE AVENUE BRYAN, TX

TOTAL DISTURBED AREA = 1.31 ACRES  
SUBDIVISION  
LOT 19, BLOCK 6  
TOTAL AREA = 56914.11 SF  
VOL. 956, PG. 430  
JOSEPH E. SCOTT LEAGUE SURVEY, A - 050  
BRYAN, BRAZOS COUNTY, TEXAS

SCALE: 1"=20'  
DATE: JUNE 2023

OWNER/DEVELOPER: DIXIE CHICKEN INC  
120 WALTON DR  
COLLEGE STATION, TX 77840  
(979) 260-7344

SURVEYOR: KERR SURVEYING, LLC  
409 N. TEXAS AVENUE  
BRYAN, TX 77803  
(979) 268-3195

ENGINEER: SCHULTZ ENGINEERING, LLC  
PO BOX 11995  
COLLEGE STATION, TX 77842  
(979)764-3900

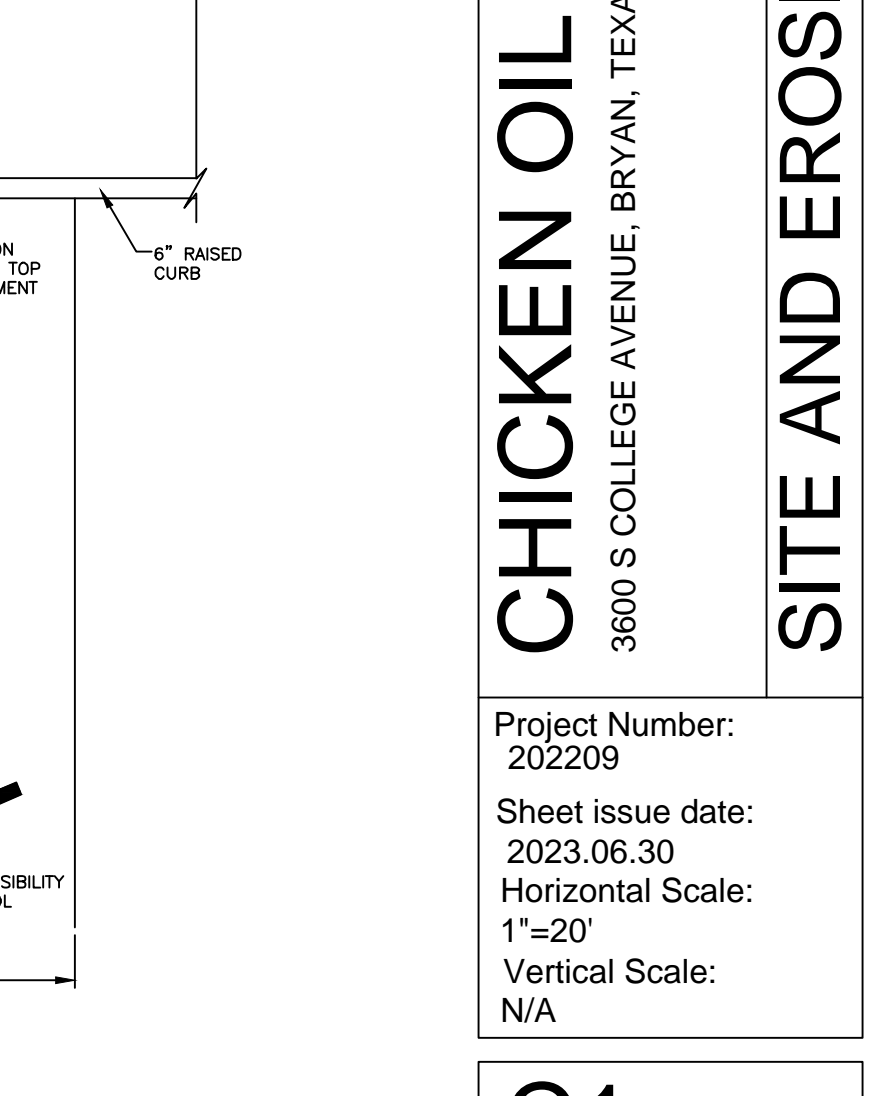
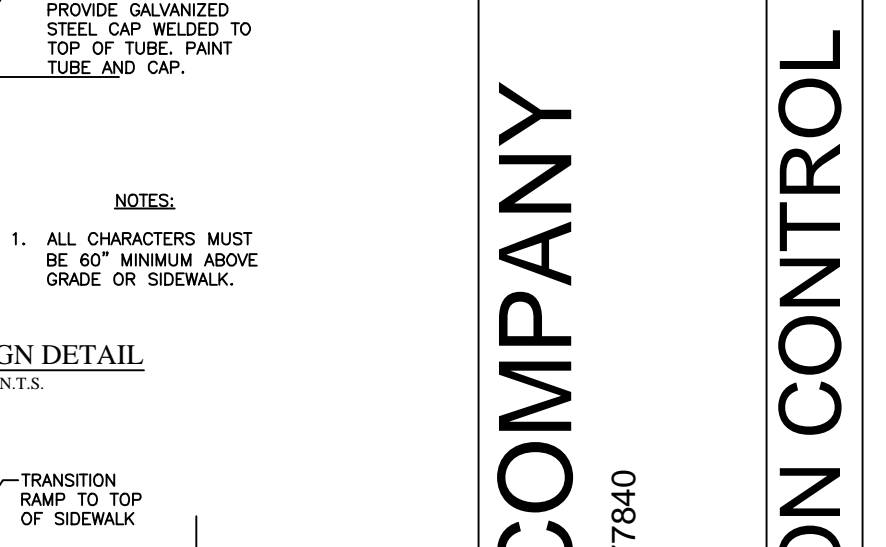
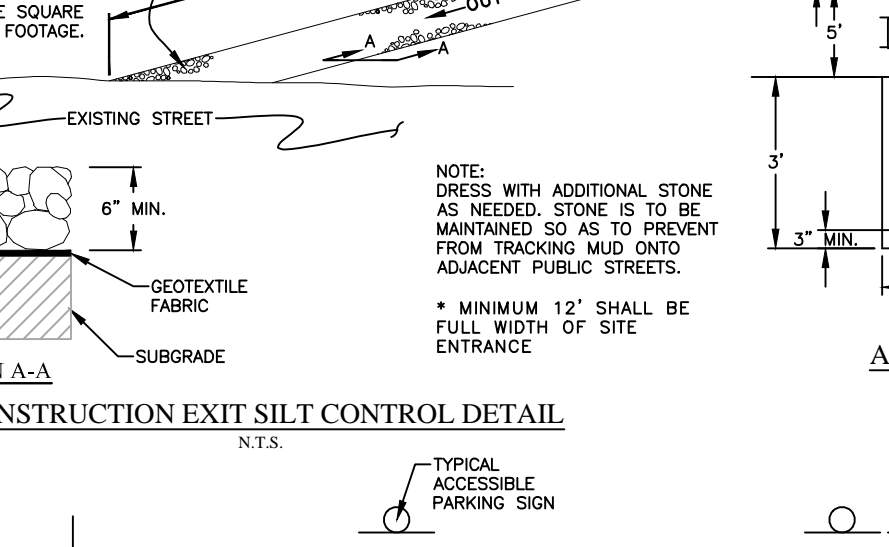
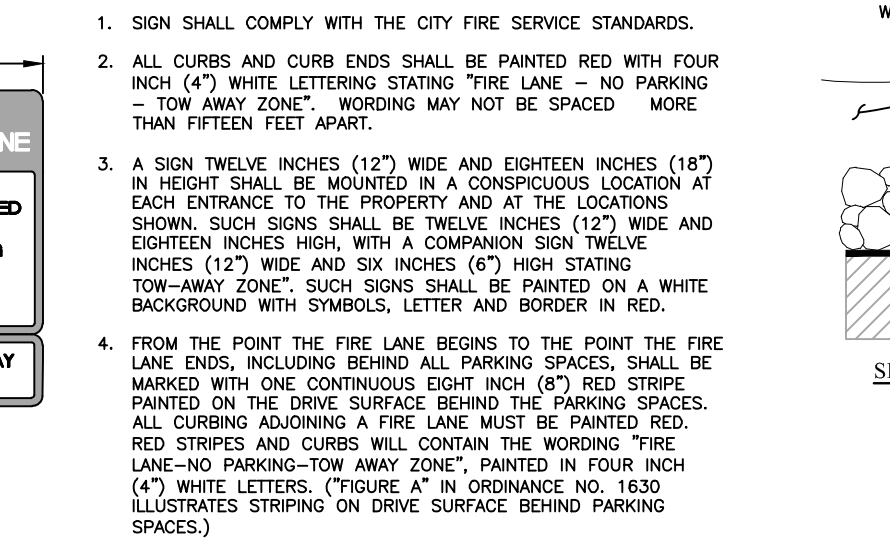
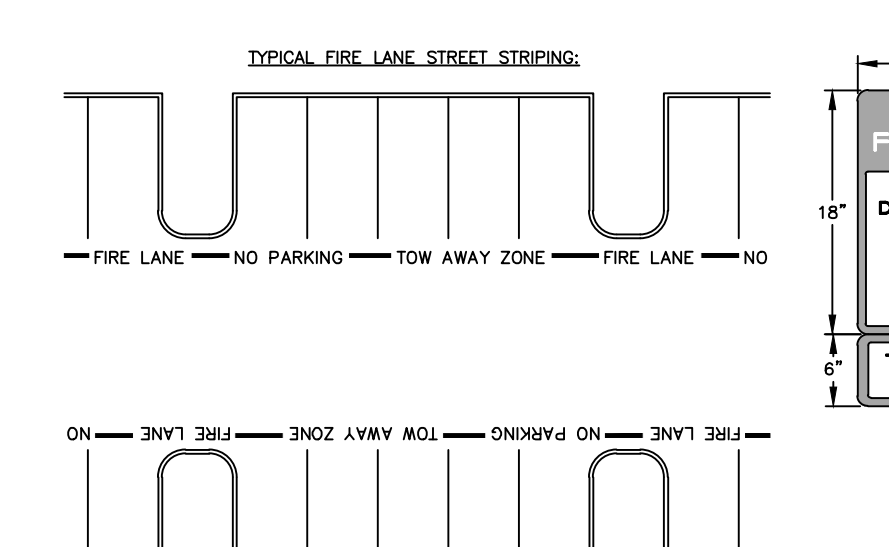
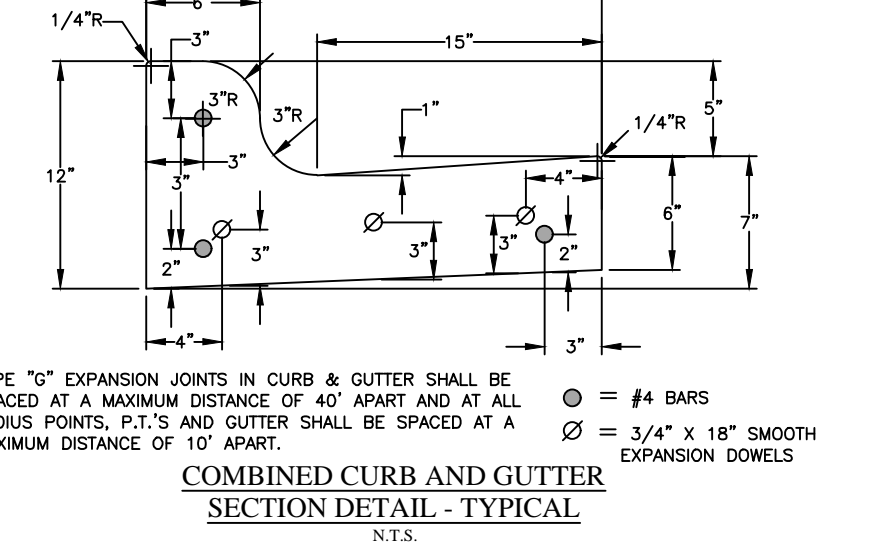
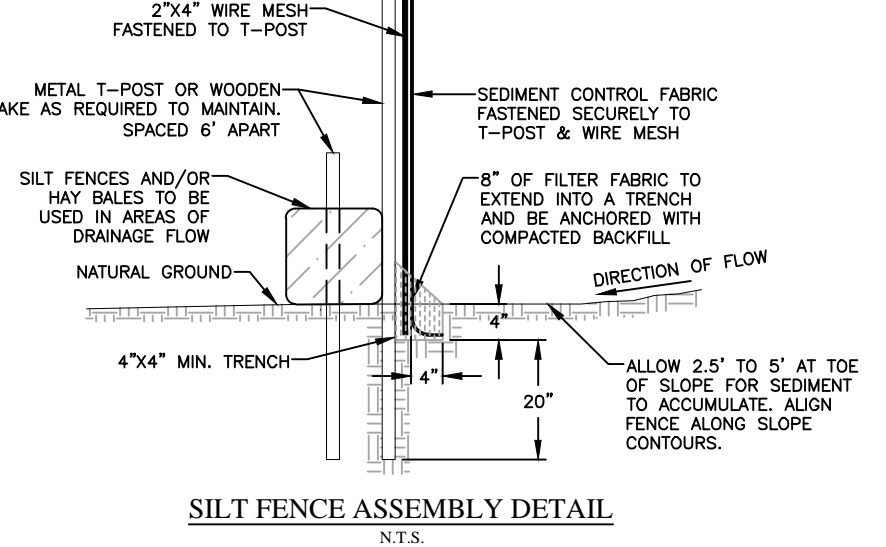
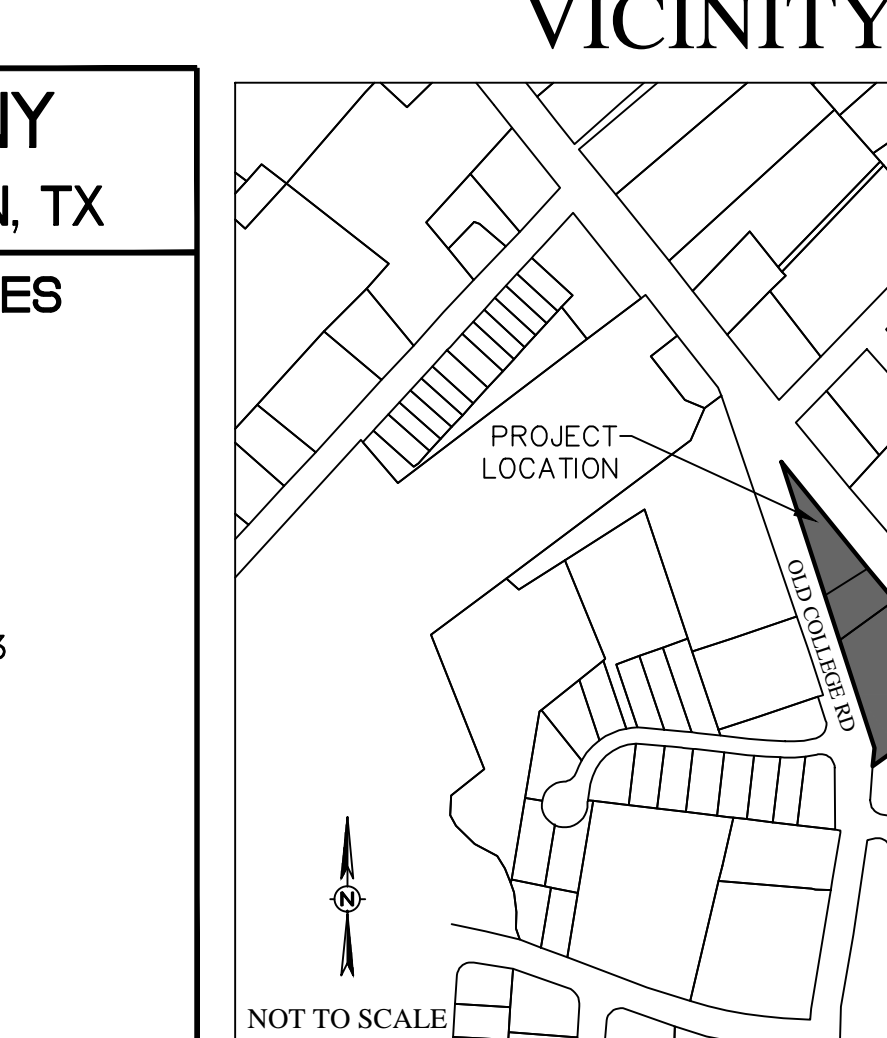



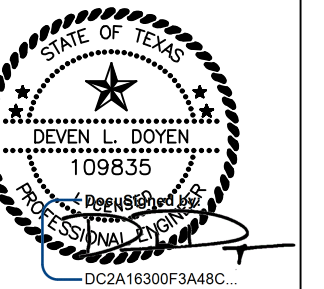

ISSUED FOR CONSTRUCTION

6/30/2023



REVISIONS

NUMBER	DATE

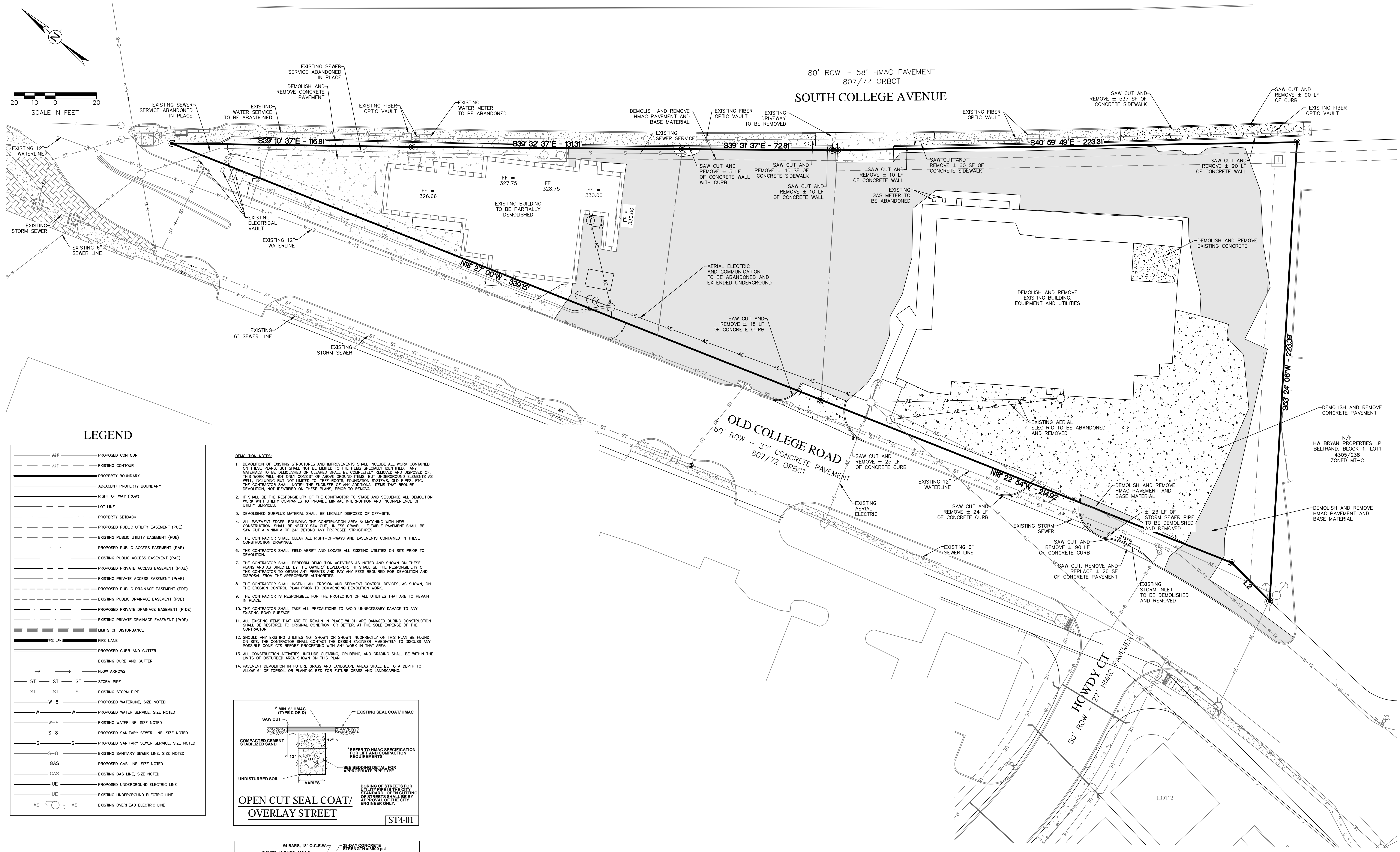

### LEGEND

---#---	PROPOSED CONTOUR
---#---	EXISTING CONTOUR
---	PROPERTY BOUNDARY
---	ADJACENT PROPERTY BOUNDARY
---	RIGHT OF WAY (ROW)
---	LOT LINE
---	PROPERTY SETBACK
---	PROPOSED PUBLIC UTILITY EASEMENT (PUE)
---	EXISTING PUBLIC UTILITY EASEMENT (PUE)
---	PROPOSED PRIVATE ACCESS EASEMENT (PAE)
---	EXISTING PRIVATE ACCESS EASEMENT (PAE)
---	PROPOSED PUBLIC DRAINAGE EASEMENT (PDE)
---	EXISTING PUBLIC DRAINAGE EASEMENT (PDE)
---	PROPOSED PRIVATE DRAINAGE EASEMENT (PDE)
---	EXISTING PRIVATE DRAINAGE EASEMENT (PDE)
---	LIMITS OF DISTURBANCE
---	FIRE LINE
---	PROPOSED CURB AND GUTTER
---	EXISTING CURB AND GUTTER
---	FLOW ARROWS
ST	STORM PIPE
ST	EXISTING STORM PIPE
W-B	PROPOSED WATERLINE, SIZE NOTED
W-B	EXISTING WATERLINE, SIZE NOTED
S-B	PROPOSED SANITARY SEWER LINE, SIZE NOTED
S-B	EXISTING SANITARY SEWER LINE, SIZE NOTED
GAS	PROPOSED GAS LINE, SIZE NOTED
GAS	EXISTING GAS LINE, SIZE NOTED
UE	PROPOSED UNDERGROUND ELECTRIC LINE
UE	EXISTING UNDERGROUND ELECTRIC LINE
AE	EXISTING OVERHEAD ELECTRIC LINE

- #### DEMOLITION NOTES:
- DEMOLITION OF EXISTING STRUCTURES AND IMPROVEMENTS SHALL INCLUDE ALL WORK CONTAINED ON THESE PLANS BUT SHALL NOT BE LIMITED TO THE ITEMS SPECIFICALLY IDENTIFIED. THIS WORK WILL NOT ONLY CONSIST OF ABOVE-GROUND ITEMS, BUT UNDERGROUND ELEMENTS AS WELL, INCLUDING BUT NOT LIMITED TO: FOUNDATIONS, FOUNDATION SYSTEMS, OLD PIPES, ETC. THE CONTRACTOR SHALL NOTIFY THE ENGINEER OF ANY ADDITIONAL ITEMS THAT REQUIRE DEMOLITION, NOT IDENTIFIED ON THESE PLANS, PRIOR TO REMOVAL.
  - IT SHALL BE THE RESPONSIBILITY OF THE CONTRACTOR TO STAGE AND SEQUENCE ALL DEMOLITION WORK WITH UTILITY COMPANIES TO PROVIDE MINIMAL INTERRUPTION AND INCONVENIENCE OF UTILITY SERVICES.
  - DEMOLISHED SURPLUS MATERIAL SHALL BE LEGALLY DISPOSED OF OFF-SITE.
  - ALL PAVEMENT EDGES BOUNDING THE CONSTRUCTION AREA & MATCHING WITH NEW CONSTRUCTION SHALL BE NEARLY SAW CUT, UNLESS OTHERWISE NOTED. FLEXIBLE PAVEMENT SHALL BE SAW CUT A MINIMUM OF 24" BEYOND ANY PROPOSED STRUCTURES.
  - THE CONTRACTOR SHALL CLEAR ALL RIGHT-OF-WAYS AND EASEMENTS CONTAINED IN THESE CONSTRUCTION DRAWINGS.
  - THE CONTRACTOR SHALL FIELD VERIFY AND LOCATE ALL EXISTING UTILITIES ON SITE PRIOR TO DEMOLITION.
  - THE CONTRACTOR SHALL PERFORM DEMOLITION ACTIVITIES AS NOTED AND SHOWN ON THESE PLANS AND AS DIRECTED BY THE OWNER/DEVELOPER. IT SHALL BE THE RESPONSIBILITY OF THE CONTRACTOR TO OBTAIN ANY PERMITS AND PAY ANY FEES REQUIRED FOR DEMOLITION AND DISPOSAL FROM THE APPROPRIATE AUTHORITIES.
  - THE CONTRACTOR SHALL INSTALL ALL EROSION AND SEDIMENT CONTROL DEVICES, AS SHOWN, ON THE EROSION CONTROL PLAN PRIOR TO COMMENCING DEMOLITION WORK.
  - THE CONTRACTOR IS RESPONSIBLE FOR THE PROTECTION OF ALL UTILITIES THAT ARE TO REMAIN IN PLACE.
  - THE CONTRACTOR SHALL TAKE ALL PRECAUTIONS TO AVOID UNNECESSARY DAMAGE TO ANY EXISTING ROAD SURFACE.
  - ALL EXISTING ITEMS THAT ARE TO REMAIN IN PLACE WHICH ARE DAMAGED DURING CONSTRUCTION SHALL BE RESTORED TO ORIGINAL CONDITION, OR BETTER, AT THE SOLE EXPENSE OF THE CONTRACTOR.
  - SHOULD ANY EXISTING UTILITIES NOT SHOWN OR SHOWN INCORRECTLY ON THIS PLAN BE FOUND ON-SITE, THE CONTRACTOR SHALL CONTACT THE DESIGN ENGINEER IMMEDIATELY TO DISCUSS ANY POSSIBLE CONFLICTS BEFORE PROCEEDING WITH ANY WORK IN THAT AREA.
  - ALL CONSTRUCTION ACTIVITIES, INCLUDING CLEARING, GRUBBING, AND GRADING SHALL BE WITHIN THE LIMITS OF DISTURBED AREA SHOWN ON THIS PLAN.
  - PAVEMENT DEMOLITION IN FUTURE GRASS AND LANDSCAPE AREAS SHALL BE TO A DEPTH TO ALLOW 6" OF TOPSOIL OR PLANTING BED FOR FUTURE GRASS AND LANDSCAPING.

